

12 6 in 1 Wireless LED Flat Par Light



User Instruction

CONTENTS

1. INSTRUCTION

Unpacking

Introduction

AC Power

Safety Instruction

Cleaning

2. FEATURE

3. SET UP

3-Pin to 5-Pin Conversion Chart

Setting up a DMX Serial Data Link

Master/Slave Fixture Linking

4. OPERATING INSTRUCTIONS

Operating modes

Product overview

Program Mode & Sound Mode

Master-Slave Operation

Master-Slave Connections and Settings

DMX Mode

5. DMX CHANNEL SUMMARY

Unpacking: Thank you for purchasing our products. Every unit has been thoroughly tested and has been shipped in perfect operating condition. Carefully check the shipping carton for damage that may have occurred during shipping. If the carton appears to be damaged, carefully inspect your fixture for any damage and be sure all accessories necessary to operate the unit has arrived intact. In the case damage has been found or parts are missing, Save the carton and all packing materials. In the event a fixture must be returned to the factory. It is important that the fixture be returned in the original factory box and packing.

Introduction: The unit is a DMX intelligent LED par can. This light can be used in a stand alone mode or connected in a Master/Slave configuration. The unit can also be controlled via DMX controller. This light has four operating modes: Sound Active mode, stand alone mode, Master/Slave and DMX control mode.

AC Power: This fixture has an auto-switching power supply that can accommodate a wide range of input voltages. The only thing necessary to do before powering on the unit is to make sure the line voltage you are applying is within the range of accepted voltages. This fixture will accommodate between 90V and 240V AC. All fixtures must be powered directly off a switched circuit and cannot be run off a rheostat (variable resistor) or dimmer circuit. Even if the rheostat or dimmer channel is used solely for a 0-100% switch.

Safety Instructions:

Please read these instructions carefully, which includes important information about the installation, usage and maintenance of this product.

- To reduce the risk of electrical shock or fire, do not expose this unit rain or moisture
- Do not spill water or other liquids into or on to your unit.
- Be sure that the local power outlet match that of the required voltage for your unit.
- Do not attempt to operate this unit if the power cord has been frayed or broken. Do not attempt to remove or break off the ground prong from the electrical cord. This prong is used to reduce the risk of electrical shock and fire in case of an internal short.
- Disconnect from main power before making any type of connection.
- Do not remove the cover under any conditions. There are no user serviceable parts inside.
- Never operate this unit when it's cover is removed.
- Never plug this unit in to a dimmer pack
- Always be sure to mount this unit in an area that will allow proper ventilation. Allow about 6" (15cm) between this device and a wall.

- Do not attempt to operate this unit, if it becomes damaged.
- This unit is intended for indoor use only, use of this product out` doors voids all warranties.
- During long periods of non-use, disconnect the unit's main power.
- Always mount this unit in safe and stable matter.
- Power-supply cords should be routed so that they are not likely to be walked on or pinched by items placed upon or against them, paying particular attention to the point they exit from the unit.
- Cleaning -The fixture should be cleaned only as recommended by the manufacturer. See page 3 for cleaning details.
- Heat -The appliance should be situated away from heat sources such as radiators, heat registers, stoves, or other appliances (including amplifiers) that produce heat.
- The fixture should be serviced by qualified service personnel when:
 - A. The power-supply cord or the plug has been damaged.
 - B. Objects have fallen, or liquid has been spilled into the appliance.
 - C. The appliance has been exposed to rain or water.
 - D. The appliance does not appear to operate normally or exhibits a marked change in performance.

Warning! To prevent or reduce the risk of electrical shock or fire, do not expose this unit to rain or moisture.

Caution! There are no user serviceable parts inside this unit. Do not attempt any repairs yourself, doing so will void your manufacturers warranty. In the unlikely event your unit may require service please contact us.

Cleaning: Due to fog residue, smoke, and dust cleaning the internal and external optical lenses must be carried out periodically to optimize light output.

1. Use normal glass cleaner and a soft cloth to wipe down the outside casing.
2. Clean the external optics with glass cleaner and a soft cloth every 20 days.
3. Always be sure to dry all parts completely before plugging the unit back in.

Cleaning frequency depends on the environment in which the fixture operates (i.e. smoke, fog residue, dust, dew).

LED PAR LIGHT

Features

•Voltage:AC90V-245V/50-60Hz

Color of LED:Red &Green&Blue&White&Amber&UV

Lamp:12pcs LEDs ,Each LED have RGBWAUV colors

Beam angle:25 degrees

Life time:>100 thousand hours

Color effect: RGBWAUV mixing

Battery level indicator on DMX menu
 Built-in DMX wireless signal receiver
 Function Effect: dimmer, strobe, eotic, gradual change,sound activeted
 Cooling mode: Natural Convection
 Flicker free for television and film
 Color: RGBWAUV color can be mixed to more than 16.7million kinds of color
 Control: DMX512, Master-slave, stand-alone, music Activate
 Channel:6/10CH
 DMX signal Input/Output: 3-pin XLR
 Feature: Cast Aluminum case, nice and wide application,less power consumption,high brightness,stable performance,long life
 Function: Color combination changer of the latest hybrid technology and excellent built-in program, strobe, gradual, pulse, cycle, color selection, music activated, electronic linear Dimmer

LED PAR LIGHT Set Up

Notice: Be sure to follow figures two and three when making your own cables. Do not use the ground lug on the XLR connector. Do not connect the cable’s shield conductor to the ground lug or allow the shield conductor to come in contact with the XLR’s outer casing. Grounding the shield could cause a short circuit and erratic behavior.

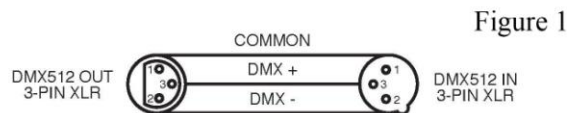

Figure 1

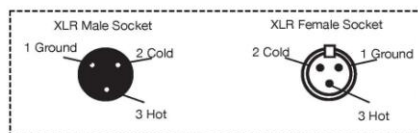

Figure 2

Figure 3

XLR Pin Configuration	
Pin 1 =	Ground
Pin 2 =	Data Compliment(negative)
Pin 3 =	Data True(positive)

3-Pin to 5-Pin Conversion Chart:

Note! If you use a controller with a 5 pin DMX output connector,you will need to use a 5 pin to 3 pin adapter. The chart below details a proper cable conversion:

3-Pin to 5-Pin Conversion

Conductor	3 Pin Female(Output)	5 Pin Male(Input)
Ground/Shield	Pin 1	Pin 1
Data(-) signal	Pin 2	Pin 2
Data(+) signal	Pin 3	Pin 3
Not Used		Do not use

Not Used		Do not use
----------	--	------------

Setting up a DMX Serial Data Link:

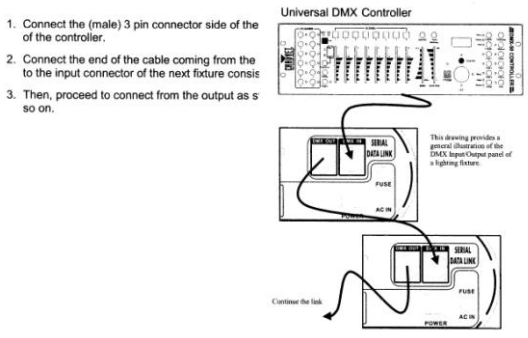

Master/Slave Fixture Linking:

1. Connect the (male) 3 pin connector side of the DMX cable to the output(female) 3 pin connector of the first fixture.
2. Connect the end of the cable coming from the first fixture which will have a (female) 3 pin connector to the input connector of the next fixture consisting of a (male) 3 pin connector. Then, proceed to connect from the output as stated above to the input of the following fixture and so on.

Operating Modes:

You can use the unit in either a stand alone mode or a master/slave configuration, there are 4 modes to choose from:

- Program Mode - Choose a static color, color show, color fade show, or color cycle. The speed of the show is adjustable. You can also have the unit strobe in this mode.
- Master/Slave Mode- Using the Master unit, choose your desired mode or program and connect the “Slave” unit or units, All slaves will now follow the”Master” unit. But only one master.
- DMX control mode - This function will allow you to control each individual fixtures traits with a standard DMX 512 controller

Product overview:

(Diagram I)

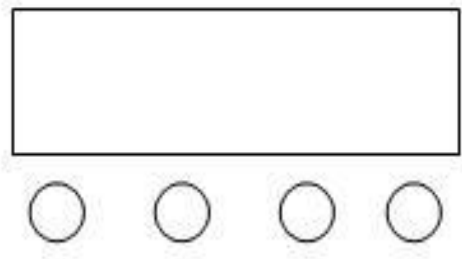

A B C D

Button		Function
<FN>	A	Used to access the mode or to return to a previous mode option
<UP>	B	Change the value of function you choosing in ascending order
<DOWN>	C	Change the value of function you choosing in descending order
<ENTER>	D	locate the function of which you want to change the value

Press the MODE button, you can browse all the function, such as AUTO RUN, DMX MODE, SLAVE MODE, SOUND

While the function you want, for example, if DMX MODE, the ADDR & MODE can be adjusted. You can press SETUP button to catch them, if MODE, it has 6 models, press UP & DOWN to locate it.

Program Mode & Sound Mode:

In Program Mode you can pick your desired factory installed program; static color, color show, color fade, or color cycle. You can apply a strobe effect to static colors, and control the speed of the color shows, color fade, and color cycle.

1. Plug the fixture in and press the MODE button till **01 static** display, you are now in program model. Press UP and DOWN to find your desired effect.
2. If you have selected a static color, press SET UP button to enter into the flash rate (F: 000-100), press UP and DOWN to adjust and select your desired flash rate.
3. When you have chosen a color show (02-17), press SET UP button, the display will show “S000-S100”, Press UP and DOWN button to adjust and set the speed. When the display shows “F000-F100”, your desired program is running in strobe effect.
4. When the display shows Sound, the unit is working in sound active mode, and the sensitivity (SENS: 00-99) is adjustable.

Master-Slave Operation:

This function will allows you to link units together to run in a Master-Slave mode. In Master-Slave operation one unit will act as the controlling unit and the others will react to the controlling units built-in programs. Any unit can act as a Master or as a Slave however, only one unit can be programmed to act as the “Master.”

Master-Slave Connections and Settings:

1. Daisy chain your units via the XLR connector on the rear of the unit. Use standard XLR microphone cables to link your units together. Remember that the Male XLR connector is the input and the Female XLR connector is the output. The first unit in the chain (master) will use the female XLR connector only. The last unit in the chain will use the male XLR connector only.
2. Using the Master unit, choose your desired mode or program and connect the “Slave” unit or

units.

3. Set the “Slave” unit(s) to the DMX address mode. They will now follow the”Master” unit.

DMX MODE:

Operating through a DMX controller give the user the freedom to create their own programs tailored to their own individual needs.

1. This function will allow you to control each individual fixture’s traits with a standard DMX 512 controller.
2. To run your fixture in DMX mode, plug in the fixture via the XLR

connections to any standard DMX controller. Press **MODE** button till **DMX MODE** display, and press **SET UP** button to enter the DMX address and DMX mode selection, and then press **UP** or **DOWN** buttons to adjust the DMX address and DMX mode. The channels value refers to the following channel summary.

LED PAR LIGHT DMX Channels Summary

1. DIAGRAM :

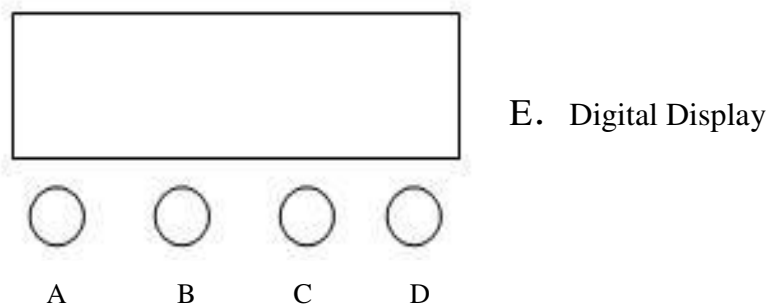

- A. Function
- B. Up
- C. Down
- D. Enter

HOW TO OPERATE?

Press button A, there will be eight different effects.
The first two numeric stands for functions (refer to Diagram II)

The last two numeric stands for DMX address, or speed.

You can modify it with B or C button..

D button is to confirm while you settled.

2. LED Display function cross-references, (D button is to confirm while you settled)

1	A001	5 channels, address adjustable by B & C button (001--512)
2	H001	9 channels, address adjustable by B & C button (001--512)
3	CC00	Seven colors jump to change, speed adjustable by B & C button (01-99)
4	CP.00	Gradual ,speed adjustable by B & C button (01—99)
5	DE.00	Color combination. Speed adjustable by B or C button(01-99)
6	BEBE	Sound activated Controlling
7	R220	Red Color Selection, While change color, with B & C button (01—99)
8	G220	Green Color Selection, While change color, with B & C button (01—99)
9	B220	Blue Color Selection, While change color, with B & C button (01—99)
10	W220	White Color Selection, While change color, with B & C button (01—99)
11	A220	Amber Color Selection, While change color, with B & C button (01—99)
12	U220	UV Color Selection, While change color, with B & C button (01—99)

3. DMX512 Channels

5 Channels:

Channels	Function	Details
CH1	Red	R dimmer, linear, dark →bright
CH2	Green	G dimmer, linear, dark →bright
CH3	Blue	B dimmer, linear, dark--bright
CH4	White	W dimmer, linear, dark--bright
CH5	Amber	Amber dimmer, linear, dark--bright
CH6	UV	UV dimmer, linear, dark--bright

9 Channels:

Channels	Function	Details
CH1	Red	R dimmer, linear, dark →bright
CH2	Green	G dimmer, linear, dark →bright
CH3	Blue	B dimmer, linear, dark--bright
CH4	White	W dimmer, linear, dark--bright
CH5	Amber	Amber dimmer, linear, dark--bright
CH6	UV	UV dimmer, linear, dark--bright
CH.7	Strobe	R、 G、 B、 W、 A、 UV strobe, slow →fast
CH.8	Dimmer	Full Dimmer
CH.9	Auto Mode	Different Auto Mode
CH.10	Speed	Function Speed, slow →fast

KEY POINT

Easy to operate, friendly design, no flicker while dimmer. stable quality.
Applicable to photograph, camera, and TV station as well.