

CE

LED moving head

ZOOM and Rotation
37pcs 40W 4-in-1

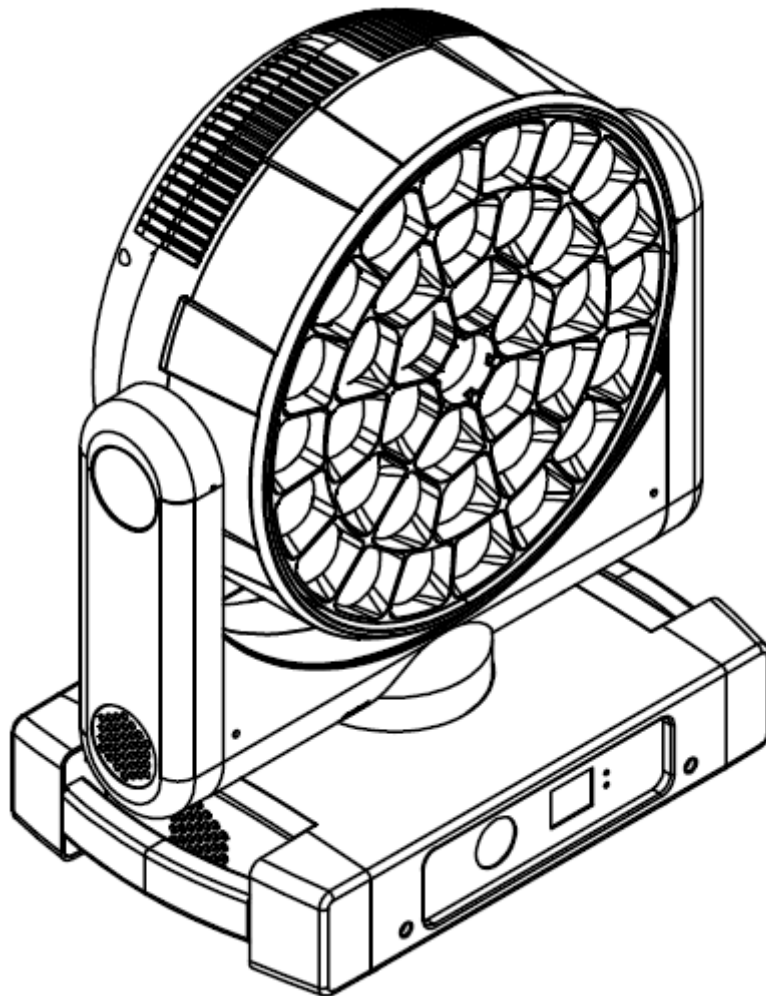

CE F IP20 LED 0.2m t_a 40°C t_c 150°C

User Manual

KEEP THIS MANUAL FOR FUTURE NEEDS

1. Unpacking

Thank you for choosing our fixture. For your own safety, please read this manual before installing the device. This manual covers the important information on installation and applications. Please install and operate the fixture with following instructions. Meanwhile, please keep this manual well for future needs.

This fixture is made of a new type of high temperature strength of engineering plastics and cast aluminum casing with nice outlook. The fixture is designed and manufactured strictly following CE standards, complying with international standard DMX512 protocol. It's available independently controlled and linkable with each other for operation. And it is applicable for large-scale live performances, theater, studio, nightclubs and discos.

4-IN-1 LEDs(RGBW) which features high brightness and stability. Please carefully unpack it when you receive the fixture and check whether it is damaged during the transportation. And please check whether the following items are included inside the box:

Moving Head-----One

Signal Cable----One

Hanging Bracket-----Two

Power Cable----One

Safety Cable-----one

User Manual----One

2. Product dimension (mm)

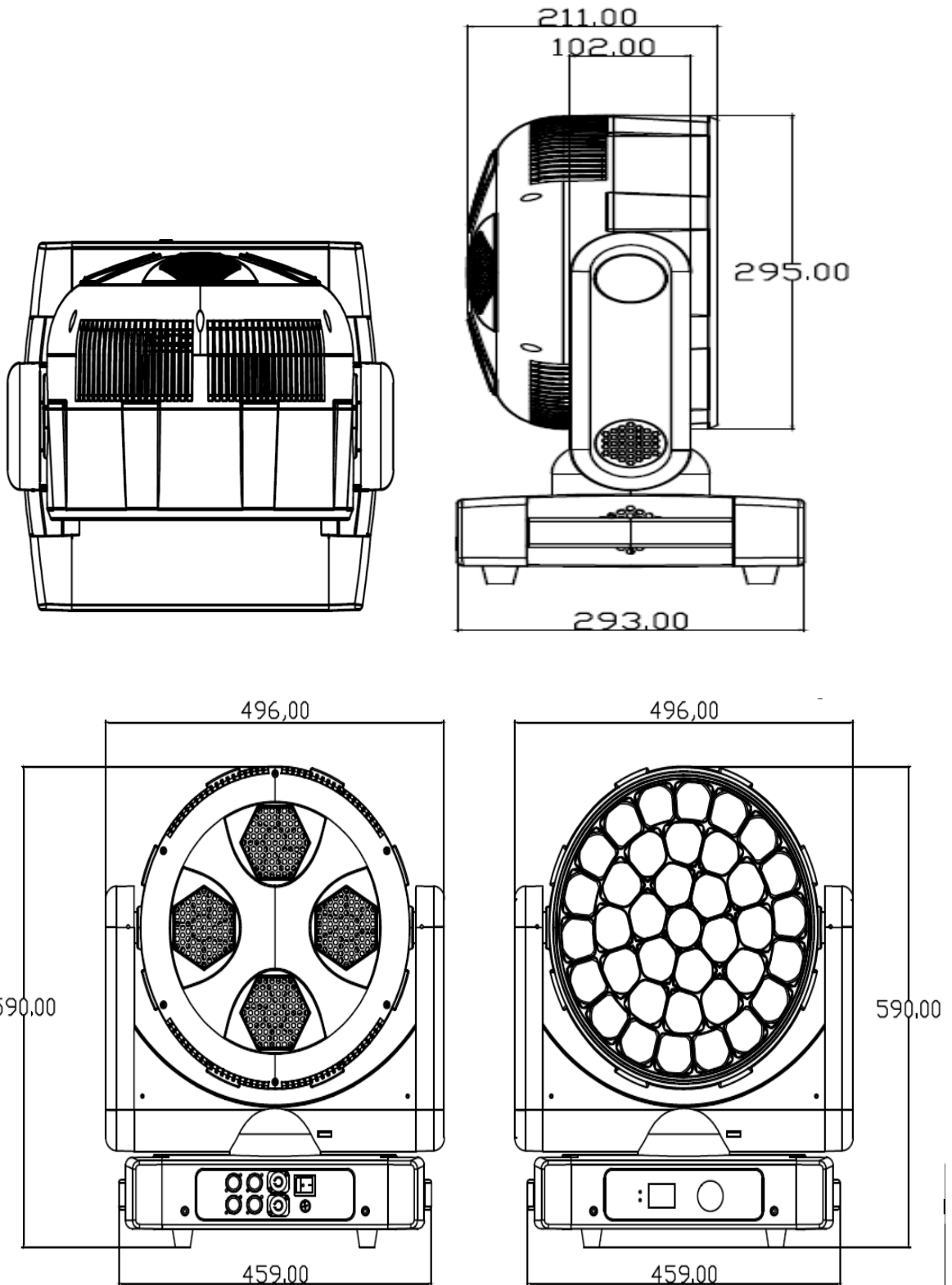

3. Safety Instructions



CAUTION!

Be careful with your operations. With a dangerous voltage you can suffer a dangerous electric shock when touching wires!

This device has left the factory in perfect condition. In order to maintain this condition and to ensure a safe operation, it is absolutely necessary for the user to follow the safety instructions and warning notes written in this user manual.



Important:

Damages caused by the disregard of this user manual are not subject to warranty. The dealer will not accept liability for any resulting defects or problems.

If the device has been exposed to temperature changes due to environmental changes, do not switch it on immediately. The arising condensation could damage the device. Leave the device switched off until it has reached room temperature.

This device falls under protection-class I. Therefore it is essential that the device be earthed.

The electric connection must carry out by qualified person.

The device shall only be used with rate voltage and frequency.

Make sure that the available voltage is not higher than stated at the end of this manual.

Make sure the power cord is never crimped or damaged by sharp edges. If this would be the case, replacement of the cable must be done by an authorized dealer.

Always disconnect from the mains, when the device is not in use or before cleaning it. Only handle the power cord by the plug. Never pull out the plug by tugging the power cord.

During initial start-up some smoke or smell may arise. This is a normal process and does not necessarily mean that the device is

defective, it should decrease gradually.

Please don't project the beam onto combustible substances.

Fixtures cannot be installed on combustible substances, keep more than 50cm distance with wall for smooth air flow, so there should be no shelter for fans and ventilation for heat radiation.

If the external flexible cable or cord of this luminaire is damaged, it shall be exclusively replaced by the manufacturer or his service agent or a similar qualified person in order to avoid a hazard.

4. Operation Instructions

-The fixture is for beam wash and effect use.

-Don't turn on the fixture if it's been through severe temperature difference like after transportation because it might damage the light due to the environment changes. So make sure to operate the fixture until it is in normal temperature.

-This light should be keep away from strong shaking during any transportation or movement.

-Don't pull up the light by only the head, or it might cause damages to the mechanical parts.

-Don't expose the fixture in overheat, moisture or environment with too much dust when installing it. And don't lay any power cables on the floor. Or it might cause electronic shock to the people.

-Make sure the installation place is in good safety condition before installing the fixture.

-Make sure to put the safety chain and check whether the screws are screwed properly when installing the fixture.

- Make sure the lens are in good condition. It's recommended to replace the units if there are any damages or severe scratch.
- Make sure the fixture is operated by qualified personnel who knows the fixture before using.
- Keep the original packages if any second shipment is needed.
- Don't try to change the fixtures without any instruction by the manufacturer or the appointed repairing agencies.
- It is not in warranty range if there are any malfunctions from not following the user manual to operate or any illegal operation, like shock short circuit, electronic shock, lamp broke, etc.

5. Mounting and Installation

Cautions: For added protection mount the fixtures in areas outside walking paths, seating areas, or in areas were the fixture might be reached by unauthorized personnel.

Before mounting the fixture to any surface, make sure that the installation area can hold a minimum point load of 10 times the device's weight.

Fixture installation must always be secured with a secondary safety attachment, such as an appropriate safety cable.

Never stand directly below the device when mounting, removing, or servicing the fixture from a
periodic safety inspection of all installation material and the fixture. If you lack these qualifications, do not attempt the installation yourself. Improper installation can result in bodily injury.

Be sure to complete all rigging and installation procedures before connecting the main power cord to the appropriate wall outlet.

Clamp Mounting: The product provides a unique mounting bracket assembly that integrates the bottom of the base, the included “Omega Bracket,” and the safety cable rigging point in one unit (see the illustration below). When mounting this fixture to truss be sure to secure an appropriately rated clamp to the included omega bracket using a M10 screw fitted through the center hole of the “omega bracket”. As an added safety measure be sure to attached at least one properly rated safety cable to the fixture using on of the safety cable rigging point integrated in the base assembly

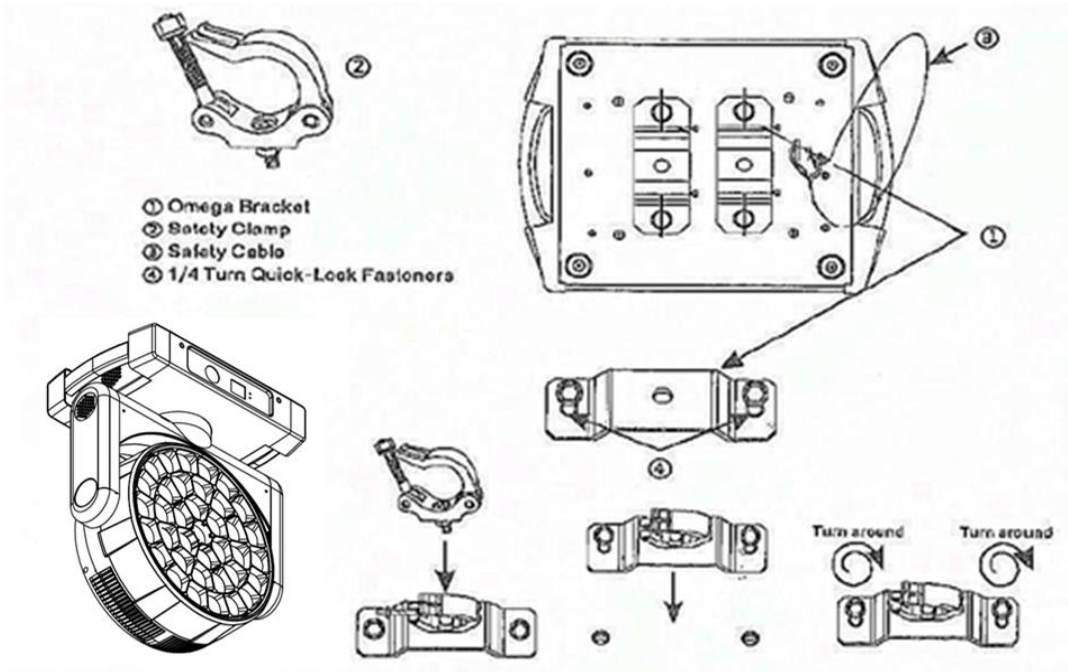

Regardless of the rigging option you choose for our fixture, always be sure to secure your fixture with a safety cable. The fixture provides a built-in rigging point for a safety cable on the hanging bracket as illustrated above. Be sure to only use the designated rigging point for the safety cable and never secure a safety cable to a carrying handle.

Regardless of the rigging option you choose for our fixture, always be sure to secure your fixture with a safety cable. The fixture provides a built-in rigging point for a safety cable on the hanging bracket as illustrated above. Be sure to only use the designated

rigging point for the safety cable and never secure a safety cable to a carrying handle.

6. DMX-512 control connections

Connect the provided XLR cable to the female 3-pin XLR output of your controller and the other side to the male 3-pin XLR input of the moving head. You can chain multiple

Moving heads be connected together through serial linking. The cable needed should be two core, screened cable with XLR input and output connectors. Please refer to the diagram below.

DMX-512 connection with DMX terminator

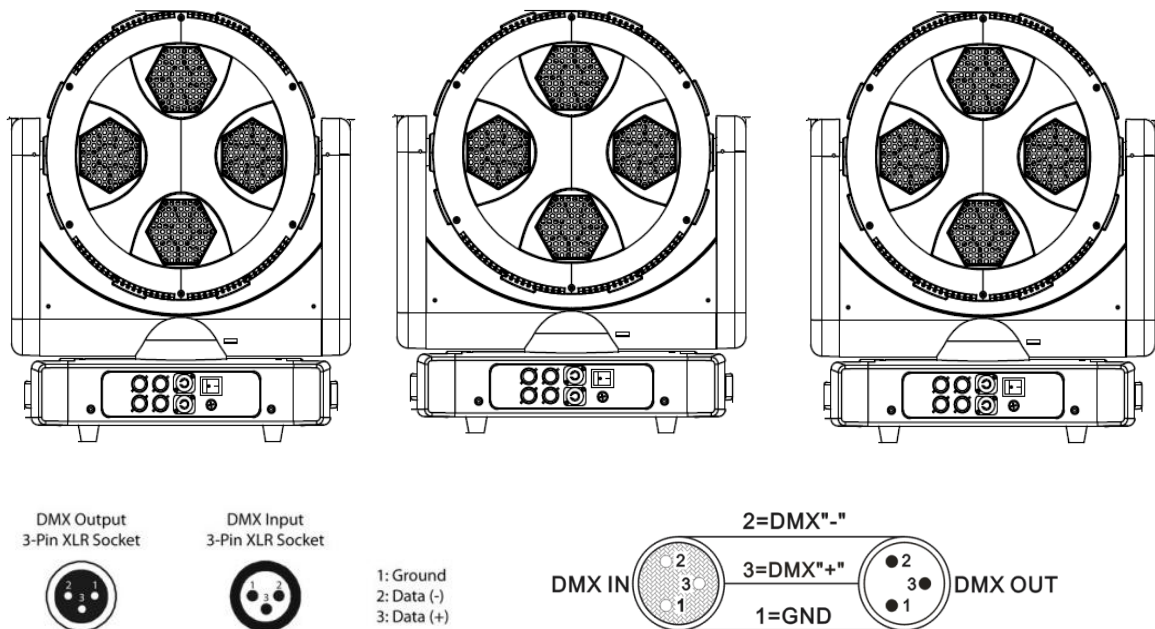

For installations where the DMX cable has to run a long distance or is in an electrically noisy environment, such as in a discotheque, it is recommended to use a DMX terminator. This helps in preventing corruption of the digital control signal by electrical noise. The DMX terminator is simply an XLR plug with a 120 Ω resistor connected between pins 2 and 3, which is then plugged into the output XLR socket of the last fixture in the chain. Please see illustrations below.

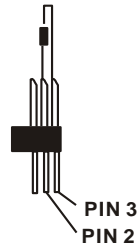
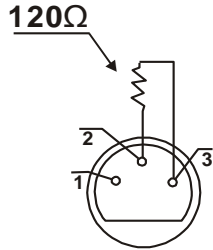

7. DMX Channels

22 channels mode

Channel	Function	DMX	Details
1	Red	0-255	1-100% Red linear dimmer from dark to bright
2	Red fine	0-255	Red fine linear dimmer from dark to bright
3	Green	0-255	1-100% Green linear dimmer from dark to bright
4	Green fine	0-255	Green fine linear dimmer from dark to bright
5	Blue	0-255	1-100% Blue linear dimmer from dark to bright
6	Blue fine	0-255	Blue fine linear dimmer from dark to bright
7	White	0-255	1-100% White linear dimmer from dark to bright
8	White fine	0-255	White fine linear dimmer from dark to bright
9	CTO	0-255	Color temperature linear control
10	Marco color	0-255	Marco color control
11	Strobe	0-3	Light up
		4-103	Strobe with the same step from slow to fast (1HZ-25HZ)
		104-107	Light on
		108-207	Split strobe speed from slow to fast (1HZ-25HZ)
		208-212	Light on
		213-225	Low -speed random strobe
		226-238	Middle speed random strobe
		239-251	High -speed random strobe
252-255	Light on		
12	Dimmer	0-255	0-100 linear dimmer from dark to bright
13	Dimmer fine	0-255	Dimmer fine control
14	Pan	0-255	Pan movement control
15	Pan fine	0-255	Pan fine control
16	Tile	0-255	Tilt movement control
17	Tile fine	0-255	Tilt fine control
18	No function	0-255	Reserved channel
19	Reset	0-25	No function
		26-76	Head Reset with 5 seconds
		77-127	Pan & Tilt Reset with 5 seconds
		128-255	All Reset with 5 seconds
20	ZOOM	0-255	ZOOM
21	Lens Rotation	0-127	0 to 60 degree
		128-190	Unlimited anticlockwise rotation from fast to slow

		191-192	Stop
		193-255	Unlimited clockwise rotation from slow to fast
22	Frequency	0-42	1K Frequency
		43-85	1.5K Frequency
		86-126	2K Frequency
		127-171	2.5K Frequency
		172-214	3K Frequency
		215-255	4K Frequency

35 channels mode

Channel	Function	DMX	Details
1	Red	0-255	1-100% Red linear dimmer from dark to bright
2	Red fine	0-255	Red fine linear dimmer from dark to bright
3	Green	0-255	1-100% Green linear dimmer from dark to bright
4	Green fine	0-255	Green fine linear dimmer from dark to bright
5	Blue	0-255	1-100% Blue linear dimmer from dark to bright
6	Blue fine	0-255	Blue fine linear dimmer from dark to bright
7	White	0-255	1-100% White linear dimmer from dark to bright
8	White fine	0-255	White fine linear dimmer from dark to bright
9	CTO	0-255	Color temperature linear control
10	Macro color	0-255	Marco color control
11	Strobe	0-3	Light up
		4-103	Strobe with the same step from slow to fast
		104-107	Light on
		108-207	Split strobe speed from slow to fast (1HZ-25HZ)
		208-212	Light on
		213-225	Low -speed random flashing
		226-238	Middle speed random flashing
		239-251	High -speed random flashing
252-255	Light on		
12	Dimmer	0-255	0-100 linear dimmer from dark to bright
13	Dimmer fine	0-255	Dimmer fine control
14	Pan	0-255	Pan movement control
15	Pan fine	0-255	Pan fine control
16	Tile	0-255	Tilt movement control
17	Tile fine	0-255	Tilt fine control
18	No function	0-255	Reserved channel
19	Reset	0-25	No function
		26-76	Head Reset with 5 seconds
		77-127	Pan & Tilt Reset with 5 seconds
		128-255	All Reset with 5 seconds
20	ZOOM	0-255	ZOOM
21	Lens Rotation	0-127	0 to 60 degree
		128-190	Unlimited anticlockwise rotation from fast to slow
		191-192	Stop
		193-255	Unlimited clockwise rotation from slow to fast

22	dynamic effect (Combine the effect color)	0-7	No function
		8	Static effect 1
		9	Static effect 2
	
		13	Static effect 6
		14	Static effect 7
		15	Dynamic effect 1
		16	Dynamic effect 2
		17	Dynamic effect 3
		18	Dynamic effect 4
		19	One alone color random
		20	Full color random
		21	Rainbow Effect 1
		22	Rainbow Effect 2
		23	Dynamic Effect 5
		24	Dynamic Effect 6
		25	Dynamic Effect 7
		26	Dynamic Effect 8
	
		58	Dynamic Effect 40
		59	Dynamic Effect 41
		60	Dynamic Effect 42
		61	Random position 1
		62	Random position 2
	
		65	Random position 5
		66	Random position 6
		67	Dynamic Effect 43
		68	Dynamic Effect 44
		69	Dynamic Effect 45
		70	Dynamic Effect 46
		71-255	No Dynamic Effect
23	Dynamic effect speed	0-63	Static effect
		64-158	Clockwise rotate from fast to slow
		159-160	Stop
		161-255	Anti-Clockwise rotate from slow to fast
24	Dynamic effect	0-255	Dynamic effect dilute
25	Shape R	0-255	Dynamic Effect R
26	Shape G	0-255	Dynamic Effect G
27	Shape B	0-255	Dynamic Effect B
28	Shape W	0-255	Dynamic Effect W
29	Shape Dimmer	0-255	Shape dimmer 0-100%
30	Background Dimmer	0-255	Background dimmer 0-100%
31	Shape transition	0-255	Dynamic effect translation
32	Shape Offset	0-255	Dynamic effect offset
33	Shape strobe	0-255	Foreground strobe control strobe(Same with 11CH)
34	Background strobe	0-255	Background strobe(Same with 11CH)
35	Background choice	0-255	Background choice

36 channels mode

Channel	Function	DMX	Details
1	Red	0-255	1-100% Red linear dimmer from dark to bright
2	Red fine	0-255	Red fine linear dimmer from dark to bright
3	Green	0-255	1-100% Green linear dimmer from dark to bright
4	Green fine	0-255	Green fine linear dimmer from dark to bright
5	Blue	0-255	1-100% Blue linear dimmer from dark to bright
6	Blue fine	0-255	Blue fine linear dimmer from dark to bright
7	White	0-255	1-100% White linear dimmer from dark to bright
8	White fine	0-255	White fine linear dimmer from dark to bright
9	CTO	0-255	Color temperature linear control
10	Macro color	0-255	Marco color control
11	Strobe	0-3	Light up
		4-103	Strobe with the same step from slow to fast
		104-107	Light on
		108-207	Split strobe speed from slow to fast (1HZ-25HZ)
		208-212	Light on
		213-225	Low -speed random flashing
		226-238	Middle speed random flashing
		239-251	High -speed random flashing
252-255	Light on		
12	Dimmer	0-255	0-100 linear dimmer from dark to bright
13	Dimmer fine	0-255	Dimmer fine control
14	Pan	0-255	Pan movement control
15	Pan fine	0-255	Pan fine control
16	Tile	0-255	Tilt movement control
17	Tile fine	0-255	Tilt fine control
18	No function	0-255	Reserved channel
19	Reset	0-25	No function
		26-76	Head Reset with 5 seconds
		77-127	Pan & Tilt Reset with 5 seconds
		128-255	All Reset with 5 seconds
20	ZOOM	0-255	ZOOM
21	Lens Rotation	0-127	0 to 60 degree
		128-190	Unlimited anticlockwise rotation from fast to slow
		191-192	Stop
		193-255	Unlimited clockwise rotation from slow to fast
22	dynamic effect (Combine the effect color)	0-7	No function
		8	Static effect 1
		9	Static effect 2
	
		13	Static effect 6
		14	Static effect 7
		15	Dynamic effect 1
		16	Dynamic effect 2
17	Dynamic effect 3		
18	Dynamic effect 4		

		19	One alone color random
		20	Full color random
		21	Rainbow Effect 1
		22	Rainbow Effect 2
		23	Dynamic Effect 5
		24	Dynamic Effect 6
		25	Dynamic Effect 7
	
		58	Dynamic Effect 40
		59	Dynamic Effect 41
		60	Dynamic Effect 42
		61	Random position 1
		62	Random position 2
	
		65	Random position 5
		66	Random position 6
		67	Dynamic Effect 43
		68	Dynamic Effect 44
		69	Dynamic Effect 45
		70	Dynamic Effect 46
		71-255	No Dynamic Effect
23	Dynamic effect speed	0-63	Static effect
		64-158	Clockwise rotate from fast to slow
		159-160	Stop
		161-255	Anti-Clockwise rotate from slow to fast
24	Dynamic effect	0-255	Dynamic effect dilute
25	Shape R	0-255	Dynamic Effect R
26	Shape G	0-255	Dynamic Effect G
27	Shape B	0-255	Dynamic Effect B
28	Shape W	0-255	Dynamic Effect W
29	Shape Dimmer	0-255	Shape dimmer 0-100%
30	Background Dimmer	0-255	Background dimmer 0-100%
31	Shape transition	0-255	Dynamic effect translation
32	Shape Offset	0-255	Dynamic effect offset
33	Shape strobe	0-255	Foreground strobe control strobe(Same with 11CH)
34	Background strobe	0-255	Background strobe(Same with 11CH)
35	Background choice	0-255	Background choice
36	Frequency	0-42	1K Frequency
		43-85	2K Frequency
		86-126	3K Frequency
		127-171	4K Frequency
		172-214	6K Frequency
		215-255	10K Frequency

132 channels mode

Channel	Function	DMX	Details
1	Red	0-255	1-100% Red linear dimmer from dark to bright
2	Red fine	0-255	Red fine linear dimmer from dark to bright
3	Green	0-255	1-100% Green linear dimmer from dark to bright
4	Green fine	0-255	Green fine linear dimmer from dark to bright
5	Blue	0-255	1-100% Blue linear dimmer from dark to bright
6	Blue fine	0-255	Blue fine linear dimmer from dark to bright
7	White	0-255	1-100% White linear dimmer from dark to bright
8	White fine	0-255	White fine linear dimmer from dark to bright
9	CTO	0-255	Color temperature linear control
10	Macro color	0-255	Marco color control
11	Strobe	0-3	Light up
		4-103	Strobe with the same step from slow to fast (1HZ-25HZ)
		104-107	Light on
		108-207	Split strobe speed from slow to fast (1HZ-25HZ)
		208-212	Light on
		213-225	Low -speed random flashing
		226-238	Middle speed random flashing
		239-251	High -speed random flashing
252-255	Light on		
12	Dimmer	0-255	0-100 linear dimmer from dark to bright
13	Dimmer fine	0-255	Dimmer fine control
14	Pan	0-255	Pan movement control
15	Pan fine	0-255	Pan fine control
16	Tile	0-255	Tilt movement control
17	Tile fine	0-255	Tilt fine control
18	No function	0-255	Reserved channel
19	Reset	0-25	No fuction
		26-76	Head Reset with 5 seconds
		77-127	Pan & Tilt Reset with 5 seconds
		128-255	All Reset with 5 seconds
20	ZOOM	0-255	ZOOM
21	Lens Rotation	0-127	0 to 60 degree
		128-190	Unlimited anticlockwise rotation from fast to slow
		191-192	Stop
		193-255	Unlimited clockwise rotation from slow to fast
22	R1 LED Dimmer	0-255	R1 LED Dimmer
23	G1 LED Dimmer	0-255	G1 LED Dimmer
24	B1 LED Dimmer	0-255	B1 LED Dimmer
...
130	R37 LED Dimmer	0-255	R37 LED Dimmer
131	G37 LED Dimmer	0-255	G37 LED Dimmer
132	B37 LED Dimmer	0-255	B37 LED Dimmer

146 channels mode

Channel	Function	DMX	Details
1	Red	0-255	1-100% Red linear dimmer from dark to bright
2	Red fine	0-255	Red fine linear dimmer from dark to bright
3	Green	0-255	1-100% Green linear dimmer from dark to bright
4	Green fine	0-255	Green fine linear dimmer from dark to bright
5	Blue	0-255	1-100% Blue linear dimmer from dark to bright
6	Blue fine	0-255	Blue fine linear dimmer from dark to bright
7	White	0-255	1-100% White linear dimmer from dark to bright
8	White fine	0-255	White fine linear dimmer from dark to bright
9	CTO	0-255	Color temperature linear control
10	Macro color	0-255	Marco color control
11	Strobe	0-3	Light up
		4-103	Strobe with the same step from slow to fast
		104-107	Light on
		108-207	Split strobe speed from slow to fast (1HZ-25HZ)
		208-212	Light on
		213-225	Low -speed random flashing
		226-238	Middle speed random flashing
		239-251	High -speed random flashing
252-255	Light on		
12	Dimmer	0-255	0-100 linear dimmer from dark to bright
13	Dimmer fine	0-255	Dimmer fine control
14	Pan	0-255	Pan movement control
15	Pan fine	0-255	Pan fine control
16	Tile	0-255	Tilt movement control
17	Tile fine	0-255	Tilt fine control
18	No function	0-255	Reserved channel
19	Reset	0-25	No fuction
		26-76	Head Reset with 5 seconds
		77-127	Pan & Tilt Reset with 5 seconds
		128-255	All Reset with 5 seconds
20	ZOOM	0-255	ZOOM
21	Lens Rotation	0-127	0 to 60 degree
		128-190	Unlimited anticlockwise rotation from fast to slow
		191-192	Stop
		193-255	Unlimited clockwise rotation from slow to fast
22	dynamic effect (Combine the effect color)	0-7	No fuction
		8	Static effect 1
		9	Static effect 2

	
		13	Static effect 6
		14	Static effect 7
		15	Dynamic effect 1
		16	Dynamic effect 2
		17	Dynamic effect 3
		18	Dynamic effect 4
		19	One alone color random
		20	Full color random
		21	Rainbow Effect 1
		22	Rainbow Effect 2
		23	Dynamic Effect 5
		24	Dynamic Effect 6
	
		59	Dynamic Effect 41
		60	Dynamic Effect 42
		61	Random position 1
		62	Random position 2
		63	Random position 3
		64	Random position 4
		65	Random position 5
		66	Random position 6
		67	Dynamic Effect 43
		68	Dynamic Effect 44
		69	Dynamic Effect 45
		70	Dynamic Effect 46
		71-255	No Dynamic Effect
23	Dynamic effect speed	0-63	Static effect
		64-158	Clockwise rotate from fast to slow
		159-160	Stop
		161-255	Anti-Clockwise rotate from slow to fast
24	Dynamic effect	0-255	Dynamic effect dilute
25	Shape R	0-255	Dynamic Effect R
26	Shape G	0-255	Dynamic Effect G
27	Shape B	0-255	Dynamic Effect B
28	Shape W	0-255	Dynamic Effect W
29	Shape Dimmer	0-255	Shape dimmer 0-100%
30	Background Dimmer	0-255	Background dimmer 0-100%
31	Shape transition	0-255	Dynamic effect translation
32	Shape Offset	0-255	Dynamic effect offset

33	Shape strobe	0-255	Foreground strobe control strobe(Same with 11CH)
34	Background strobe	0-255	Background strobe(Same with 11CH)
35	Background choice	0-255	Background choice
36	R1 LED Dimmer	0-255	R1 LED Dimmer
37	G1 LED Dimmer	0-255	G1 LED Dimmer
38	B1 LED Dimmer	0-255	B1 LED Dimmer
...
...
144	R37 LED Dimmer	0-255	R37 LED Dimmer
145	G37 LED Dimmer	0-255	G37 LED Dimmer
146	B37 LED Dimmer	0-255	B37 LED Dimmer

169 channels mode

Channel	Function	DMX	Details
1	Red	0-255	1-100% Red linear dimmer from dark to bright
2	Red fine	0-255	Red fine linear dimmer from dark to bright
3	Green	0-255	1-100% Green linear dimmer from dark to bright
4	Green fine	0-255	Green fine linear dimmer from dark to bright
5	Blue	0-255	1-100% Blue linear dimmer from dark to bright
6	Blue fine	0-255	Blue fine linear dimmer from dark to bright
7	White	0-255	1-100% White linear dimmer from dark to bright
8	White fine	0-255	White fine linear dimmer from dark to bright
9	CTO	0-255	Color temperature linear control
10	Macro color	0-255	Marco color control
11	Strobe	0-3	Light up
		4-103	Strobe with the same step from slow to fast (1HZ-25HZ)
		104-107	Light on
		108-207	Split strobe speed from slow to fast (1HZ-25HZ)
		208-212	Light on
		213-225	Low -speed random flashing
		226-238	Middle speed random flashing
		239-251	High -speed random flashing
252-255	Light on		
12	Dimmer	0-255	0-100 linear dimmer from dark to bright
13	Dimmer fine	0-255	Dimmer fine control
14	Pan	0-255	Pan movement control
15	Pan fine	0-255	Pan fine control
16	Tile	0-255	Tilt movement control
17	Tile fine	0-255	Tilt fine control
18	No function	0-255	Reserved channel
19	Reset	0-25	No fuction
		26-76	Head Reset with 5 seconds
		77-127	Pan & Tilt Reset with 5 seconds
		128-255	All Reset with 5 seconds

20	ZOOM	0-255	ZOOM
21	Lens Rotation	0-127	0 to 60 degree
		128-190	Unlimited anticlockwise rotation from fast to slow
		191-192	Stop
		193-255	Unlimited clockwise rotation from slow to fast
22	R1 LED Dimmer	0-255	R1 LED Dimmer
23	G1 LED Dimmer	0-255	G1 LED Dimmer
24	B1 LED Dimmer	0-255	B1 LED Dimmer
25	W1 LED Dimmer	0-255	W1 LED Dimmer
...
166	R37 LED Dimmer	0-255	R37 LED Dimmer
167	G37 LED Dimmer	0-255	G37 LED Dimmer
168	B37 LED Dimmer	0-255	B37 LED Dimmer
169	W37 LED Dimmer	0-255	W37 LED Dimmer

8. Display instruction

Menu	Sub-Menu	Secondary	Function
		submenu	
Return	Address	001-512	
	Return	DMX Value/Signal/Channel/Model/Temp	
	EN/中	English & Chinese can be chosen	
	Auto/Normal		
	Set up		
Adjust	Password		
Setup	Run Mode	Artnet/DMX/Artnet+DMX/Auto1/Auto2/Sound	
	Channel Mode	22CH/35CH/36CH/132CH/146CH/169CH	
	Pan Def Pos	000-255	
	Tilt Def Pos	000-255	
	Invert Pan	YES/NO	
	Invert Tilt	YES/NO	
	Swap Pan/Tilt	YES/NO	
	P/T Speed Mode	YES/NO	
	Keep signal	YES/NO	
	Encodor Correct	YES/NO	
	Hall Correct	YES/NO	
	Fast Dimming	YES/NO	

	Backlighting time	15s/30s/60s/OFF
	Dimmer Curve	Curve1/Curve2/Curve3/Curve4
	Lamp Mode	OFF/750W/1000W/1200W/2000W/2500W
	Load default	
Test	22CH/35CH/36CH/132CH/146CH/169CH	Manually test each channel mode
Advanced	Network	IP:002.000.000.001/MS:255.000.000.000
	Universe	Net(0-127):000/Sub_Unit:000
	Reset Head	
	Reset XY	
	Reset All	
Sys Info	Error message	
	DMX data	
	Sensor information	
	Softwear Ver:20-04-04-00	
	Hardwear Ver:10-10-01-00	

9. Photometric Data:

LUX Data of 7 degree beam angle

R	31000lux@2m	18600lux@4m	8500lux@6m
G	56000lux@2m	35000lux@4m	16300lux@6m
B	90000lux@2m	63500lux@4m	30000lux@6m
W	83000lux@2m	59000lux@4m	27600lux@6m
RGBW	158000lux@2m	118500lux@4m	72000lux@6m

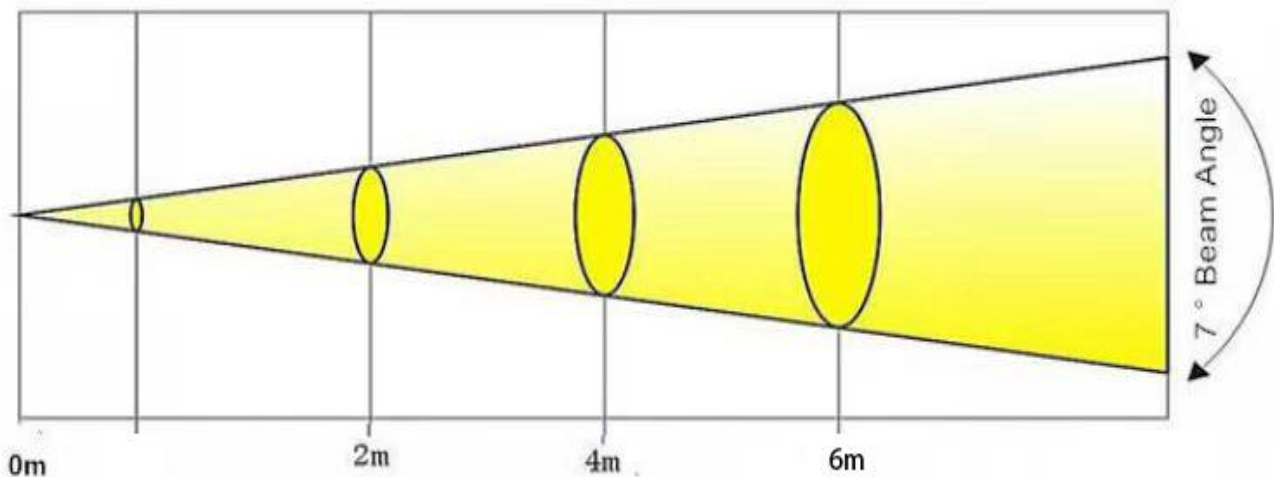

10. Key Features

Voltage: AC100V~240V 50-60HZ

Rated Power: 1450W

LED Source: 37x40W high power RGBW 4 in 1 LEDs

Zoom: 7°-50°

Strobe: 0-25Hz

Control Mode: DMX512, Sound-actived, Master/slave

DMX Channels: 22/35/36/132/146/169 six channel mode

Dimmer: 0-100% linear dimmer with 4 kinds of dimmer curve.

Pan: 540°+16bit fine

Tilt: 250°+16bit fine

Display: LCD display with touch buttons.

Temperature control: intelligent temperature control, which can automatically adjust the speed and overheating protection of the heat fan.

IP: IP20

Fixture dimension: 496*293*590cm

N.W: 26 Kg

G.W: 30.8 Kg

Package dimension: 61.5*61.5*54CM (1pc/ctn)

Special Points.

1. Each LED can be controlled individually. With unique honeycomb designed lens
2. The front lens can rotate without limitation in forward and reverse direction to create amazing effects
3. Can be used as beam, wash or effect light use (Kaleido effects)

11. Maintenance and Cleaning

The following points have to be considered during the inspection:

1. All screws for installing the devices or parts of the device have to be tightly connected and must not be corroded. 2. There must not be any deformations on the housing, color lenses, fixations and installation spots (ceiling, suspension, trussing). 3. Mechanically moved parts must not show any traces of wearing and must not rotate with unbalances. 4. The electric power supply cables must not show any damage, material fatigue or sediments.

Further instructions depending on the installation spot and usage have to be adhered by a skilled installer and any safety problems have to be removed.



CAUTION!

Disconnect from mains before starting maintenance operation.

In order to make the lights in good condition and extend the life time, we suggest a regular cleaning to the lights.

- 1) Clean the inside and outside lens each week to avoid the weakness of the lights due to accumulation of dust.
- 2) Clean the fan each week.
- 3) A detailed electric check by approved electrical engineer each three month, make sure that the circuit contacts are in good condition, prevent the poor contact of circuit from overheating.

We recommend a frequent cleaning of the device. Please use a moist, lint- free cloth. Never use alcohol or solvents. There are no serviceable parts inside the device. Please refer to the instructions under “Installation instructions”. Should you need any spare parts, please order genuine parts from your local dealer